

CONTRACT SERIES TWO

Medium Fascia Roller Shade

12v Low Voltage / Solar / Li-Ion Motorized Control



The precision engineered Rollease Acmeda Contract Series Two is the culmination of 40 years of engineering experience offering the newest technology with best in class aesthetics and industry leading features. The CS2 Medium Fascia system, with a max width of 120" (based on a 120" drop) up to 92 Sq.Ft. before linking options with the ability to link multiple panels at angles up to 90°. The CS2 Medium Fascia system utilizes our P95 Fascia and has the ability to be a "reverse roll fascia", enabling you to be able to maneuver the shade forward to avoid window and door hardware when necessary. Also, it can be a "fabric covered valance fascia", enhancing the design of the of the space. This precision engineered system, integrates a powerful, yet quiet motor, directly in the tubing of the roller which is powered through a plug-in transformer or hardwired by an EC with connector plug. The sleek, compact form with consistent bracket, and OD tube diameter fosters a clean, consistent look across of all possible shading sizes in its range.

Features:

- With a max width of 120" (based on a 120" drop) up to 92 SqFt. before linking options.
- Linking options include in-line coupling.
- Industry leading narrowest equal light gap of 1/2" per side.
- Automate line of low voltage (12V) motors from 2 NM to 10 NM for large applications with ultra-quiet operation and ARC bi-directional communication.
- Optional solar panel for environmentally forward, energy efficient constant system charging.
- Self-locating installation feature with 10mm idler extension (1mm increments)
- Fabric Spline feature provides positive attachment of fabric to tube.
- Accepts standard and reverse roll applications



Match this solution with any of our sunscreen, blackout or high performance fabrics for a complete finished solution. See our document library for comprehensive information including HPD, LEED & NRC specifications.

FINISH COLORS



MOTOR OPTIONS

Automate Wall Switches
[Hand held or wall mounts]



DC Power Panel
[Provides power for 18 DC ARC motors]



Automate Solar Charger
[energy efficient]



Automate ARC Repeater
[Extends the ARC signal]



ARC Relay Module
[Smart System Interface]

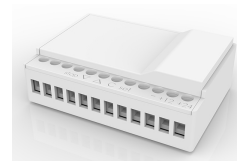

Automate Pulse Hub
[Smart Phone Control]



FRONT & SIDE VIEW

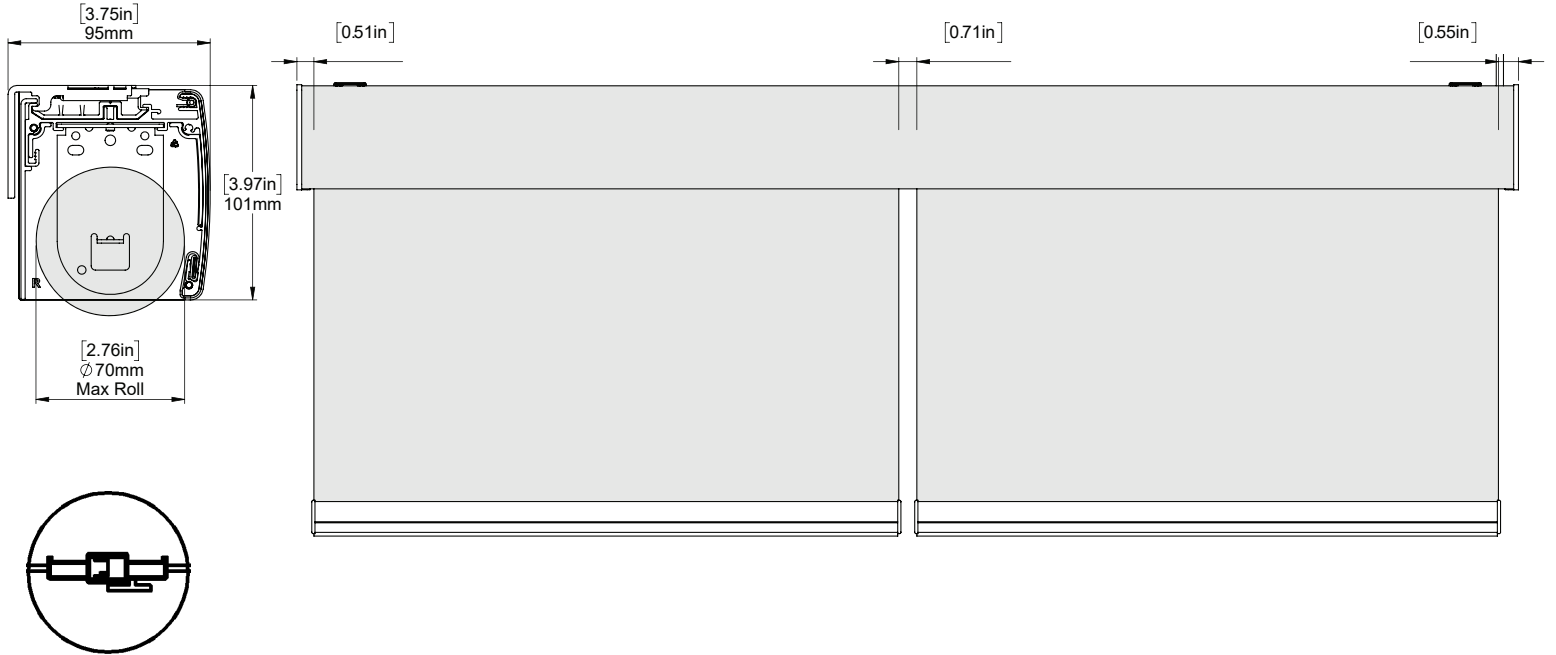

SCHEMATIC

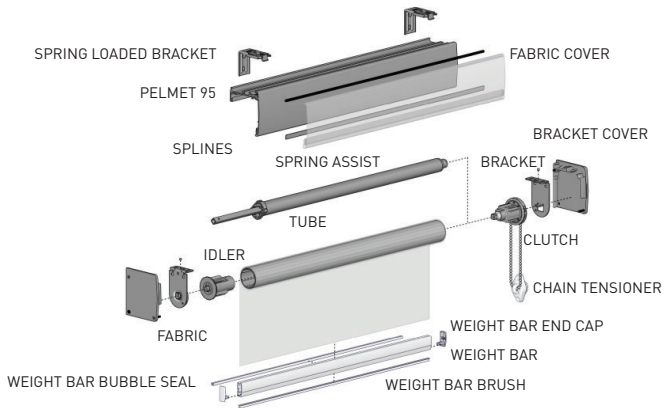

BOTTOM RAIL OPTIONS

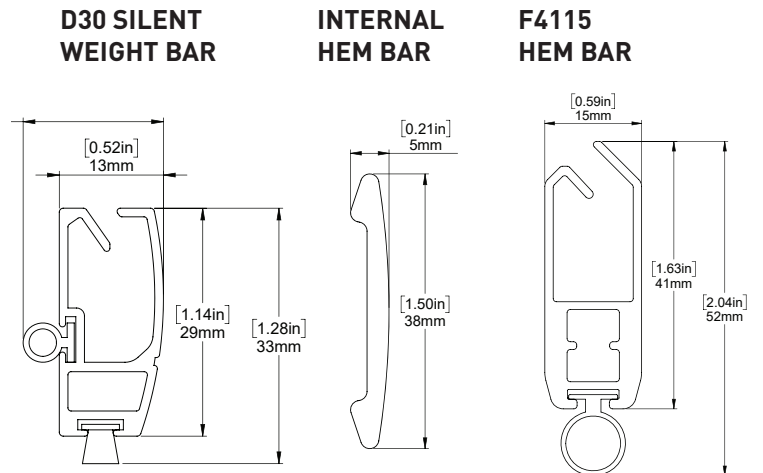

SYSTEM UPGRADES

5" Pocket
[for hidden recess mounts]



L & I Clips
[for hidden recess mounts]



Edge Side Channels
[for improved light blackout]



Internal Wire Guide
[supporting complex shading systems]



Fabric Spline System
[secure attachment of fabric on a roller shade]



For more information about our Upgrade solutions, see our UPGRADE SPECIFICATION sheets.