

# CONTRACT SERIES TWO

## Medium Fascia Roller Shade

Line Voltage 120V AC Motorized Control



The precision engineered Rollease Acmeda Contract Series Two Medium Fascia system is a durable and robust combination of form and function in a sleek package. The CS2 Medium Fascia system utilizes our P95 Fascia and has the ability to be a “reverse roll fascia”, enabling you to be able to maneuver the shade forward to avoid window and door hardware when necessary. Also, it can be a “fabric covered valance fascia”, enhancing the design of the of the space. This precision engineered system, integrates a powerful, yet quiet motor, directly in the tubing of the roller which is powered through plug in transformer or hardwired by an EC with connector plug. With a max width of 120" (based on a 120" drop) up to 92 sq.ft. before linking options. Featuring minimal light gaps, this properly balanced precision system will last a lifetime with reduce service calls /issues. Significantly heavier and impressive shading systems require precision engineered, heavy duty hardware, that can support multiples of its own weight.

### Features:

- With a max width of 110" (based on a 120" drop) up to 92 SqFt. before linking options.
- Linking options include in-line, angled up to 45° and up to 90° coupling.
- Industry leading narrowest equal light gap of 1/2" per side.
- Automate line of line voltage (120V AC) motors from 6Nm to 50Nm for large applications with ultra-quiet operation and ARC bi-directional communication.
- Self-locating installation feature with 10mm idler extension (1mm increments)
- Fabric Spline feature provides positive attachment of fabric to tube.
- Accepts standard and reverse roll applications



Match this solution with high performance fabrics for a complete window solution. See our document library for comprehensive information including HPD, LEED & NRC specifications.

## MOTOR OPTIONS

### Automate Wall Switches

[Hand held or wall mounts]



### Automate ARC Repeater

[Extends the ARC signal]



### ARC Relay Module

[Smart System Interface]

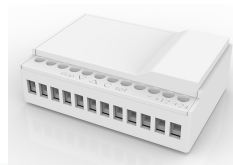

### Automate Pulse Hub

[Smart Phone Control]



## FINISH COLORS



## FRONT & SIDE VIEW

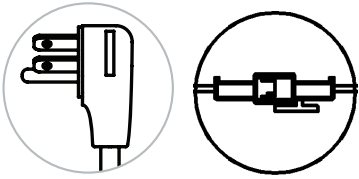

## SCHEMATIC

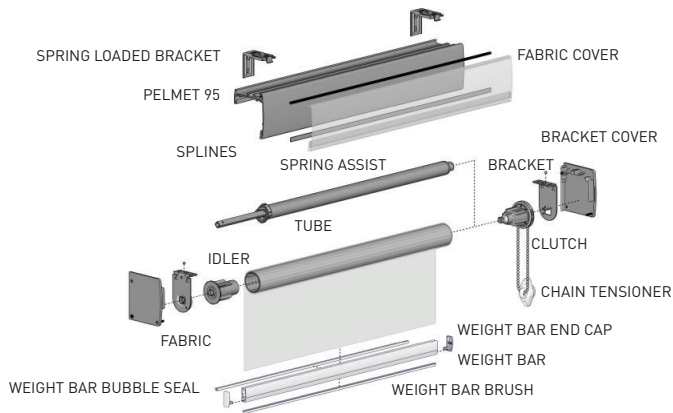

## BOTTOM RAIL OPTIONS

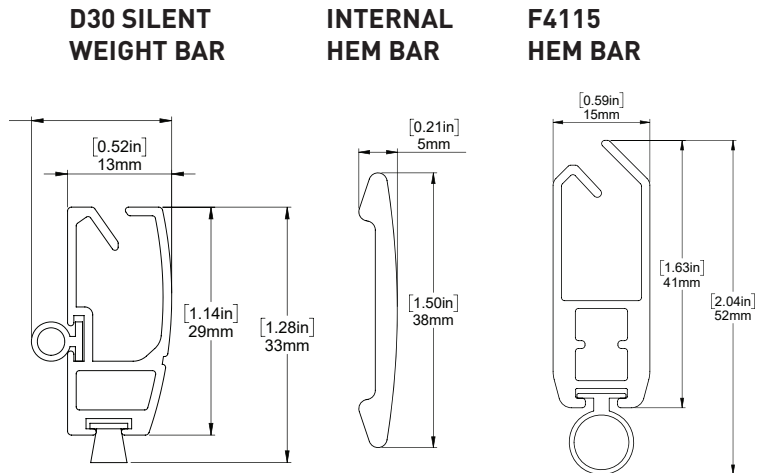

## SYSTEM UPGRADES

**5" Pocket**  
[for hidden recess mounts]



**L & I Clips**  
[for hidden recess mounts]



**Edge Side Channels**  
[for improved light blackout]



**Internal Wire Guide**  
[supporting complex shading systems]



**Fabric Spline System**  
[secure attachment of fabric on a roller shade]

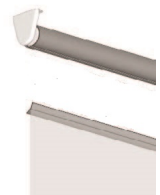

For more information about our Upgrade solutions, see our UPGRADE SPECIFICATION sheets.