

CONTRACT SERIES ONE

Medium Open Roller Shade

12 Volt Low Voltage / Solar/ Li-Ion Motorized Control



The precision engineered Rollease Acmeda Contract Medium Open Roll system is a durable and robust combination of form and function in a sleek package. With a myriad of powering options our commercial duty Contract Series One system supports low voltage powering through custom power panels, plug in transformers, solar powered PV arrays or our game changing rechargeable Li-ion internal batter system. With a max width of 120" (based on a 120" drop) up to 100 sqf. before linking options. Featuring minimal light gaps, this properly balanced precision system will last a lifetime with reduced service calls /issues. Significantly heavier and impressive shading systems require precision engineered, heavy duty hardware, that can support multiples of its own weight.

Features:

- With a max width of 120" (based on a 120" drop) up to 100 sqf. before linking options.
- Linking options for single and dual shade configurations.
- Automate motor Ultra-quiet operation with ARC bi-directional communication.
- Optional solar panel for environmentally forward, energy efficient constant system charging.
- Accepts standard or reverse roll configurations for versatile and efficient installation.
- Newly designed Heavy Duty Idler assembly consists of Teflon and glass filled nylon to eliminate noise and resist wear and tear for the life of the shading system.
- Driven by our Automate Low Voltage line of motors from 2 NM to 10 NM for large applications

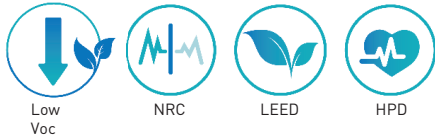
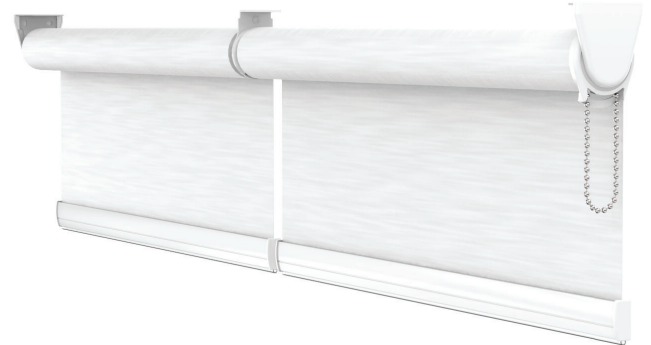

Match this solution with any of our sunscreen, blockout or high performance fabrics for a complete finished solution. See our document library for comprehensive information including HPD, LEED & NRC specifications.

BRACKET COLORS



MOTOR OPTIONS

Automate Wall Switches
[Hand held or wall mounts]



DC Power Panel
[Provides power for 18 DC ARC motors]



Automate Solar Charger
[energy efficient]



Automate ARC Repeater
[Extends the ARC signal]



ARC Relay Module
[Smart System Interface]

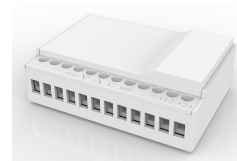

Automate Pulse Hub
[Smart Phone Control]



FRONT & SIDE VIEW

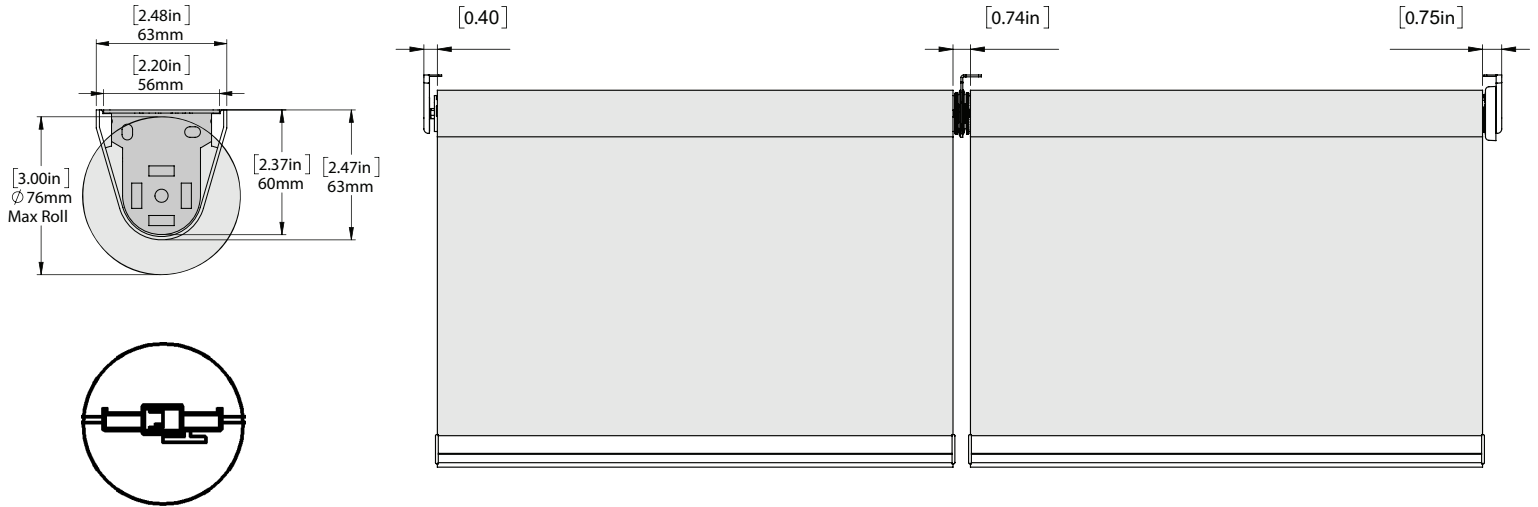

SCHEMATIC

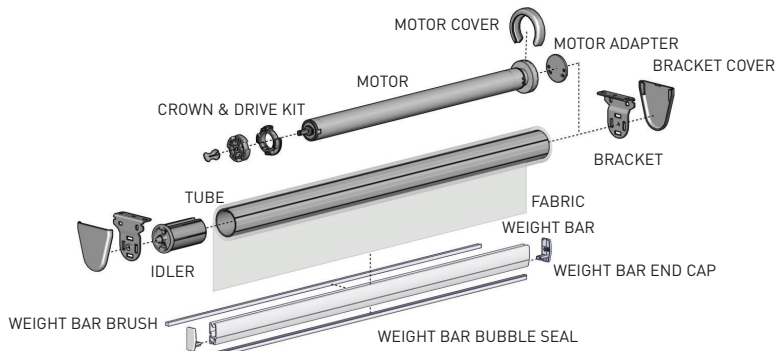

BOTTOM RAIL OPTIONS

D30 SILENT WEIGHT BAR

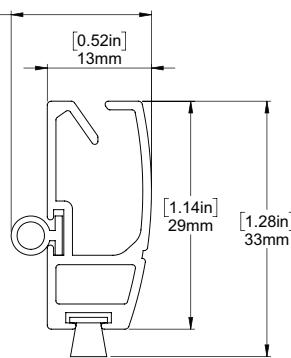

INTERNAL HEM BAR

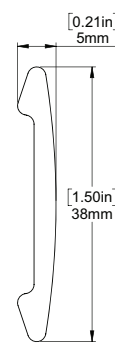

F4115 HEM BAR

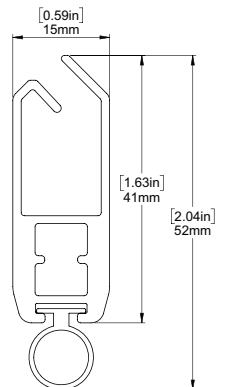

SYSTEM UPGRADES

5" Pocket

[for hidden recess mounts]



L & I Clips

[for hidden recess mounts]



Edge Side Channels

[for improved light blackout]



Internal Wire Guide

[supporting complex shading systems]



Fabric Switch System

[fast easy changing of fabric on a roller shade]

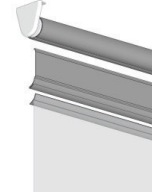

For more information about our Upgrade solutions, see our UPGRADE SPECIFICATION sheets.